

RocketGuard130

User' Manual

HighPoint

Revision: 1.2

Date: March. 2007

HighPoint Technologies, Inc.

Copyright

Copyright © 2007 HighPoint Technologies, Inc. All materials in this manual are protected and their rights are reserved according to International Copyright Laws. No part of this manual may be reproduced, transmitted or transcribed in any form and (or) for any purpose without the express written permission of HighPoint Technologies, Inc.

Trademarks

Companies and products mentioned in this manual are for identification purpose only. Product names or brand names appearing in this manual may or may not be registered trademarks or copyrights of their respective owners. Backup your important data before using HighPoint's products and use at your own risk. In no event shall HighPoint be liable for any loss of profits, or for direct, indirect, special, incidental or consequential damages arising from any defect or error in using HighPoint's products or manuals. Information in this manual is subject to change without notice and does not represent a commitment on the part of HighPoint. If any information in this manual is subject to change without notice, HighPoint assumes no liability on the part.

Notice

Reasonable effort has been made to ensure that the information in this manual is accurate. HighPoint assumes no liability for technical inaccuracies, typographical, or other errors contained herein.

Business Statement

HighPoint offers the industry's broadest storage solutions, from innovative management and monitoring tools, RAID controllers, external storage and software, extending storage functionality and value.

The RocketGuard130 will help provide continuity and flexibility in running your company's systems and hardware. Providing remote access in conjunction with a RocketRAID Controller card, the RocketGuard130 gives remote access, a highly essential feature in today's cutthroat market. Companies thriving on remote access can control their servers from just about anywhere, eliminating constraints at the office while streamlining data resource management. The RG130 gives businesses tools to monitor their systems, supplying vital information about the system fans, temperature ranges, and the status of available power supplies. In addition, the RG130 couples these sensors and detectors with ways to monitor and maintain the system health of your vital servers, reducing both time and cost. The RG130 is platform independent and remotely accessible, making it easier to connect to the system. The RG130 was created to reduce downtime and optimize performance with minimal cost to your organization.

Preface

About This Manual

This manual is including the functions, capabilities, installation overview, configurations and maintenance of the RocketGuard130. Please refer to the products pages on our web sites (<http://www.highpoint-tech.com>) for updates or some other supports. This product is intended to be professionally installed.

Manual Organization

Chapter 1 describes the features, specifications and functions of the RocketGuard130.

Chapter 2 provides hardware information. It includes the Block Diagram, the hardware layout and RocketGuard130 installation instructions.

Chapter 3 includes installation instructions of RocketGuard130 driver and HighPoint IPMI Management Software.

Chapter 4 provides the using descriptions of HighPoint IPMI Management Software.

Chapter 5 introduces the JAVA installation.

Chapter 6 lists contacting information of HighPoint Technologies.

Manual Convention

Special attention should be given to the following symbols for proper installation and to prevent damage done to the components or injury to you:



Warning: Important information given to ensure proper system installation or to prevent damage to the components.

Note: Additional information given to differentiate various models or to ensure correct system setup.

Table of Contents

Chapter 1

Introduction

1-1 Checklist	1-1
1-2 Introduction of RocketGuard130	1-2
1-3 Product Features	1-2
1-4 Compatibility List	1-3

Chapter 2

Hardware Description

2-1 Block Diagram	2-1
2-2 RocketGuard130 Layout	2-2
2-3 RocketGuard130 Quick Reference	2-4
2-4 Installation	2-5

Chapter 3

Installation of Driver and Software

3-1 Installing the driver of RocketRAID	3-1
3-2 Installing HighPoint IPMI Management Software	3-1
3-3 Updating the RocketGuard130 Firmware/Altering device settings.....	3-6 3-6

Chapter 4

HighPoint IPMI Management Software

4-1 Overview	4-1
--------------------	-----

4-2 Host Management	4-1
4-3 Login	4-5
4-4 Session Management	4-6
4-5 Remote Boot Console	4-7
4-6 Event Log	4-9
4-7 Time Stamp	4-11
4-8 System Health Management	4-11
4-9 Network Configuration.....	4-14
4-10 BMC Information.....	4-15
4-11 User Management	4-15
4-12 SNMP	4-17
4-13 SOL Console	4-18
4-14 Firewall.....	4-21

Chapter 5

Appendix

5-1 Steps of installing java under redhat.....	5-1
5-2 Steps of installing Java under Windows.....	5-2

Chapter 6

Customer Support

6-1 Troubleshooting Checklist.....	6-1
------------------------------------	-----

Chapter 1 Introduction

1-1 Checklist

Please check the contents of the RocketGuard 130 package. If any of the components listed below are damaged or missing, please contact your retailer.

All included with Retail Box Only:

CATEGORY	NAME	NOTE
	 RocketGuard 130 Card	
Cables	 2x2 Switch cables	
	 Two pieces of PC Cables	PC-1 & PC-2
	 DB9 Female Cables	
Accessories	One Bracket	Standard PCI Bracket
Application CD	Manuals, Drivers and Utilities	
Manual	The User Guide	

1-2 Introduction of RocketGuard130

During the continually developing of servers, more and more users not only regard monitoring the chassis environmental factors of the servers, but also expect to monitor and control many remote systems' environmental factors by only one terminal computer. RocketGuard130 is a solution for this requirement. Users can monitor the chassis environmental factors of remote systems by a terminal computer. Such as, fans speed, temperature of the chassis and main components, the power supply status etc.

1-3 Product Features

- Serial Over LAN
- Supports SNMP trap (multiple destinations)
- Monitoring the current voltage and status of power supply with I²C
- Monitoring the temperature of main components in the enclosure (Need additional sensor board)
- Support up to six fans' speed detection
- Fan speed could be full speed or half speed according to enclosure temperature
- Remote chassis power On/Off and remote chassis reset
- Remote O.S Power Off , remote O.S power cycle and remote O.S reset
- Support up to 5 different users. And support 4 privilege levels

-
- Support up to 4 users to do the operations at the same time
 - Fan fail LEDs indicators
 - Key pad connector

1-4 Compatibility List

The RocketGuard130 is compatible with the following RocketRAID Controllers:

- RocketRAID 2220
- RocketRAID 2240
- RocketRAID 2320
- RocketRAID 2310

The RocketGuard130 is compatible with motherboards produced by the following manufacturers:

- Asus
- Tyan
- SuperMicro
- MSI
- Intel

Note: The motherboard must support Console Redirection, otherwise SOL Console features cannot be enabled.

The RocketGuard130 works with the follow Operating Systems

- Windows (XP, 2000, 2003; 64 or 32 bit)
- Linux SuSE Enterprise 9, 10
- Linux Redhat Enterprise 3 and 4
- Linux Fedora Core up to 5

Chapter 2 Hardware Description

2-1 Block Diagram

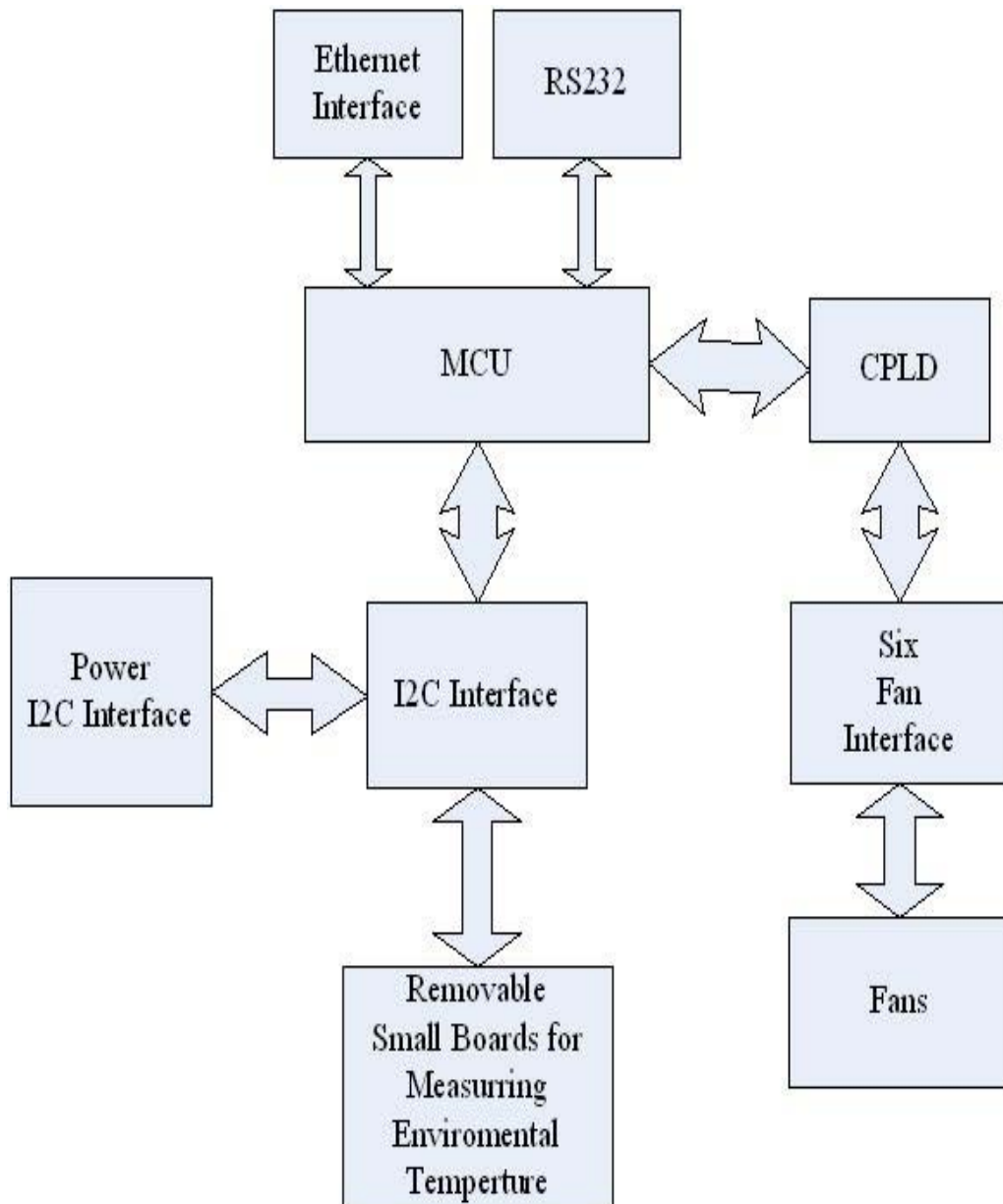

Fig.1 Block Diagram

Note: This is a general block diagram and may not exactly represent the feature on your RocketGuard130.

2-2 RocketGuard130 Layout

Top View:

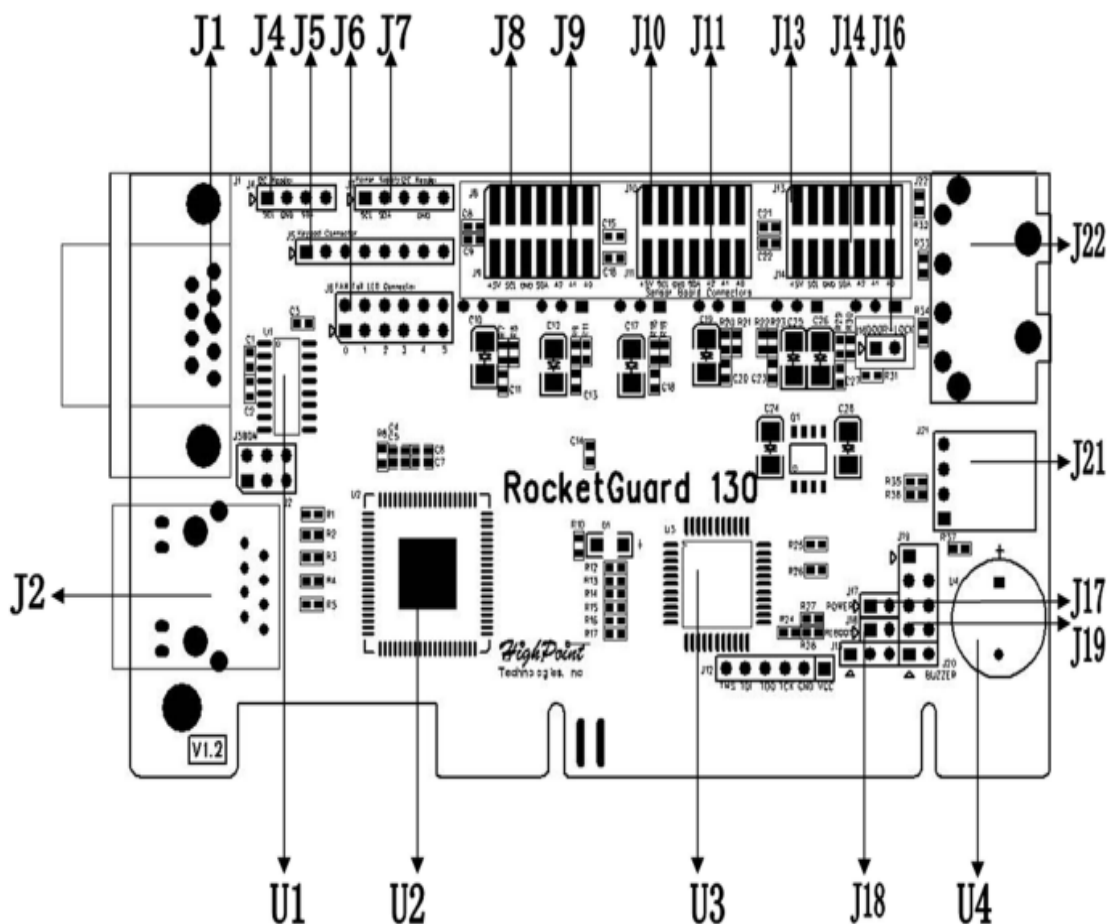

Fig.2 RocketGuard130 Hardware top view

Bottom View:

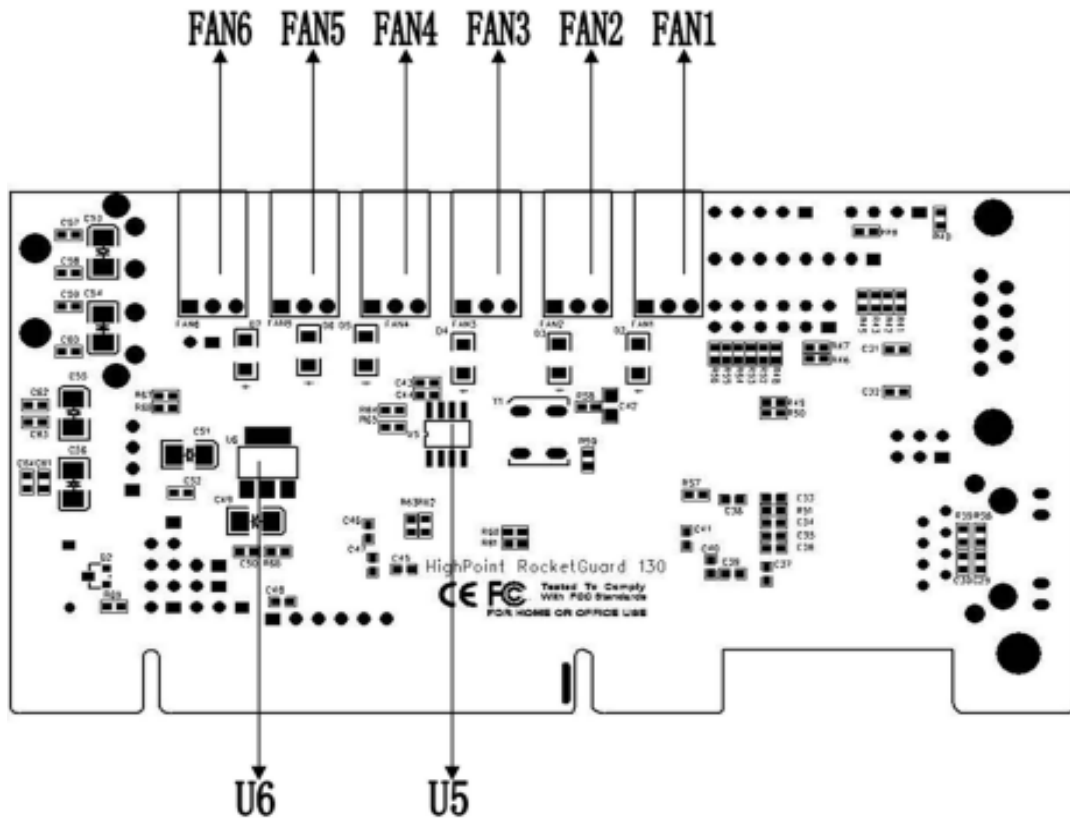

Fig3. RocketGuard130 Hardware bottom view

Note:

- All layouts shown in this manual were based upon the latest PCB Revision available at the time of publishing. The RocketGuard130 you have received may or may not look exactly the same as the graphics shown in this manual.
- See the following pages for the detailed information about the hardware.

2-3 RocketGuard130 Quick Reference

Hardware' s serial Number	Function
U1	RS232 Transmitter/Receiver
U2	MCU
U3	CPLD
U4	Buzzer on Board
U5	Digital Temperature Sensor
U6	Voltage Regulator
J1	DB-9 connector
J2	RJ45 Ethernet Interface
J4	I2C Interface for Host Adapter
J5	Key PAD interface
J7	I2C interface for Power Supply
J8, J9, J10, J11, J13, J14	I2C Interface for Small Temperature Sensor Boards
J16	Door-lock Interface
J17	Power-control interface, connect to the "Power Switch" in the chassis.
J18	Reset-control interface, connect to the "Reboot Switch" in the chassis.
J19	This interface Includes Power-control and Reset-control. Detailed introduction is in next part.
J21	Little 4-pin Power Connector
J22	Big 4-pin Power Connector
FAN1, FAN2, FAN3, FAN4, FAN5, FAN6	Fan Interfaces

2-4 Installation

1. Insert the RocketGuard130 into an available PCI slot on the motherboard (see the diagram below).

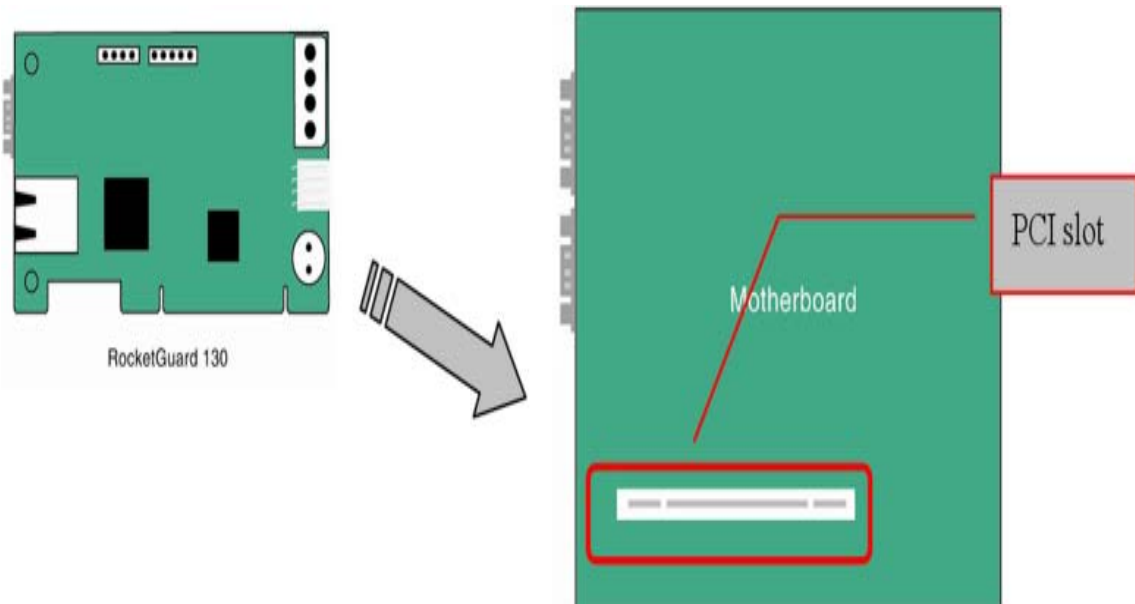

2. Insert the I²C power supply, I²C header, power connectors, Ethernet interface and fan Interface cables to the RocketGuard130. Refer to the diagram below:

Front View:

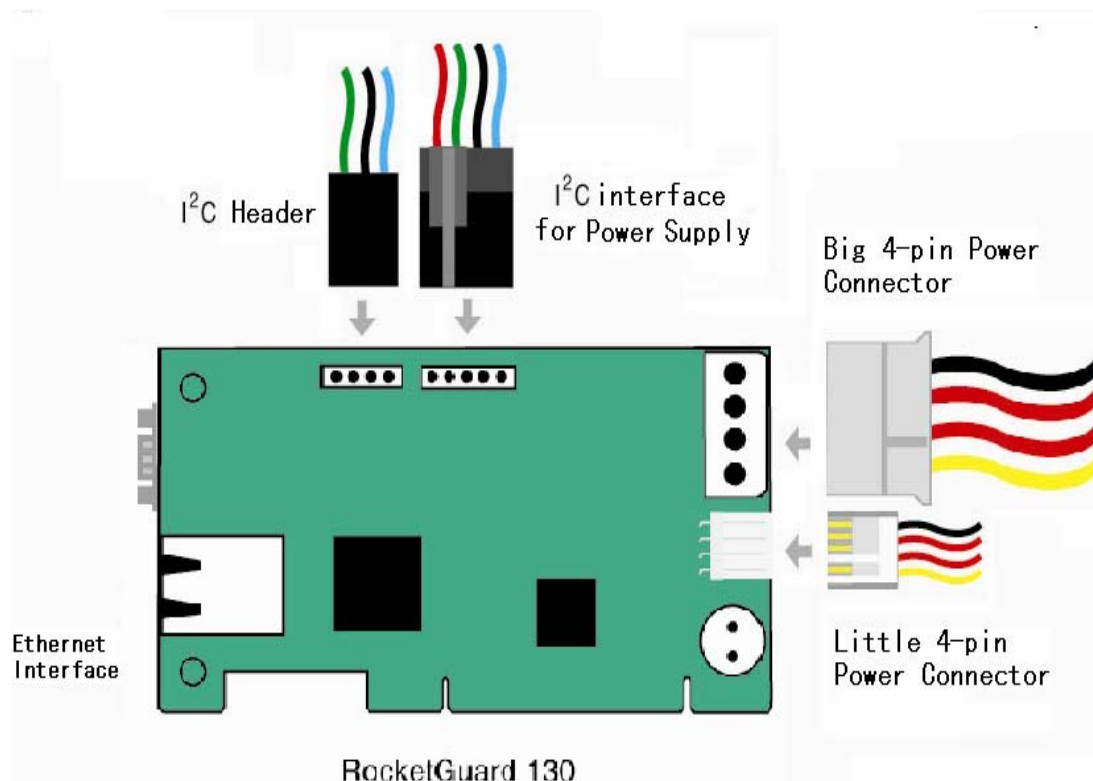

Rear View:

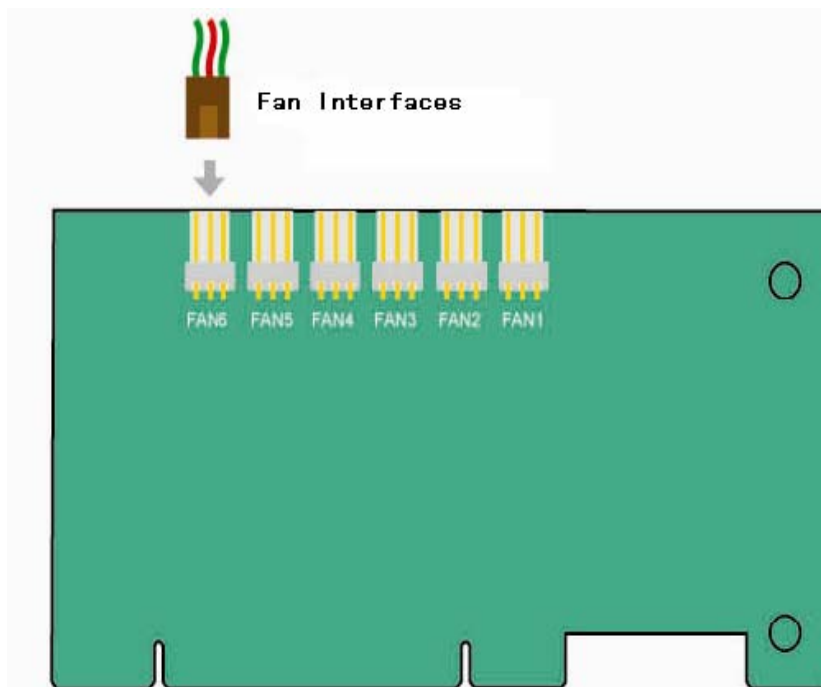

3. Connect the network cable to connector J2. This will allow access to the RG130's settings/functions via a LAN/Internet connection.

4. Connect the system's power supply to either J21 or J22.



Warning: We strongly recommended using only one connection for the system's power supply – use either J21 or J22, not both.

5. Connect the appropriate I²C cable to connector J4. Insert the other side of the cable into the RocketRAID host adapter's I²C port.

Two different I²C Cables are provided:

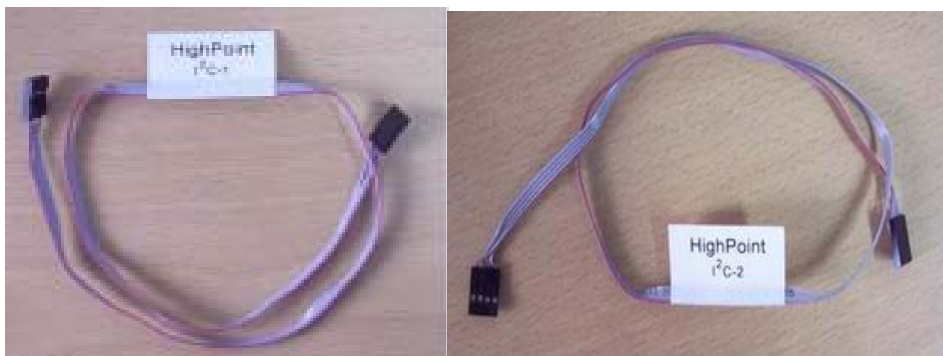

Each cable was designed for use with different HighPoint RocketRAID host adapters. For example: Cable I²C-1 (left, above) should be used with the RocketRAID2240 and RocketRAID2320/2310 models, while I²C-2 (right, above) should be used with the RocketRAID2220.



Warning: Note the red line printed on each cable – this end of the I²C cable should be inserted into the SCL pin (Pin1).

Example (RocketRAID 2240 and RocketGuard 130):

Pin1	Pin2	Pin3	Pin4
SCL	GND	SDA	NC

6. Connect J7 to the 5-pin I²C interface for power supply.

Pin1	Pin2	Pin3	Pin4	Pin5
SCL	SDA	NC	GND	NC

7. J19 is discussed in detail below. This interface Includes Power-control and Reset-control:

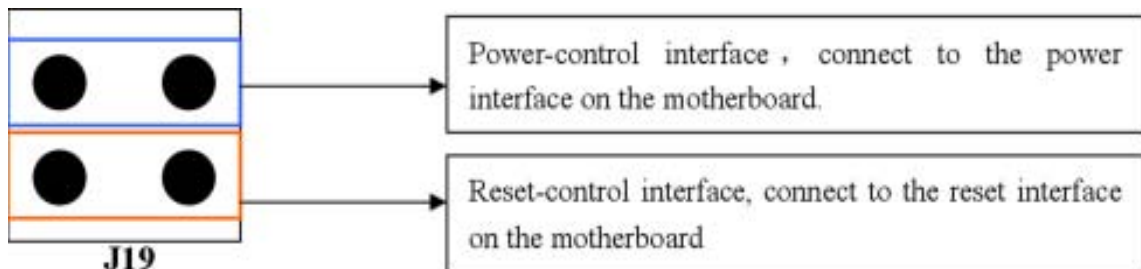

Warning: On the motherboard, the red line must connect to the positive pole; the black line connects to the cathode pole as the following figure shows.

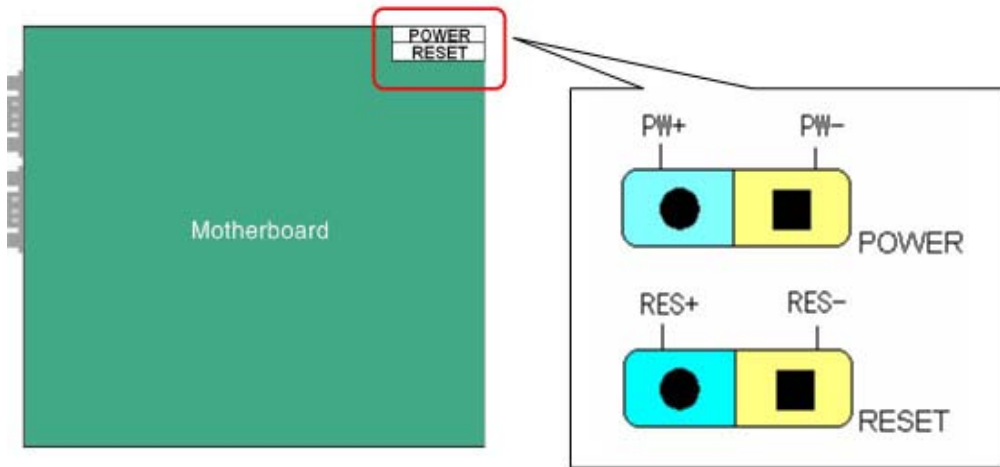

8. Connect the J17 and J18 to the “Power Switch” and “Reboot Switch” in the chassis respectively.

9. FAN1 – FAN6 – Six ports are provided to monitor the system’s cooling fans:

Pin1	Pin2	Pin3
Tachometer	+12V	Speed control

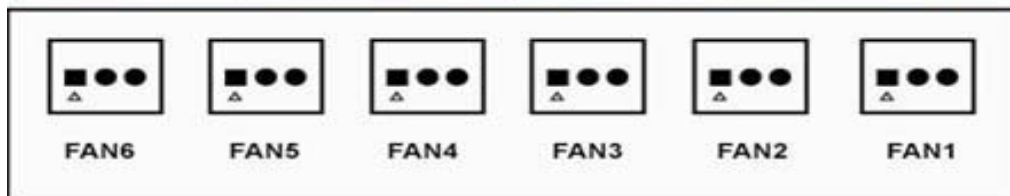
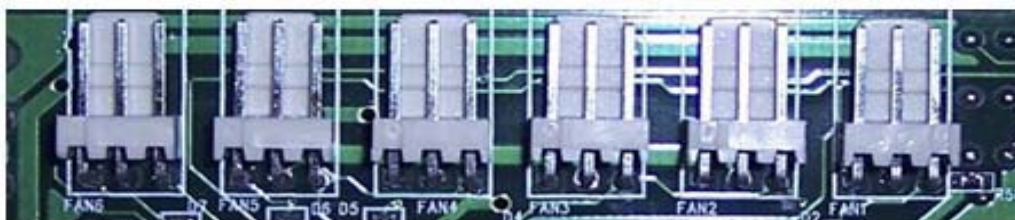

Chapter 3

Installation of Driver and Software

3-1 Installing the driver of RocketRAID

We recommended that RocketGuard130 be used in conjunction with RocketRAID Series Host Adapters, such as the RocketRAID2220, RocketRAID2320 and RocketRAID 2240. The following features are disabled when the RocketGuard is used as a stand-alone device:

1. RocketGuard130 firmware updates
2. Graceful Power Control
3. Setting time automatically when the Server is on. (Write the server's time into RocketGuard130)

Note: The functions *Graceful Power Control* and *Time Setting* are integrated with the RocketRAID Series Host Adapter's WebGUI (v1.4 or later).

If you want to take full advantage of the RocketGuard130, please use in conjunction with a RocketRAID Series Host Adapter, and the corresponding WebGUI.

3-2 Installing HighPoint IPMI Management Software

The HighPoint IPMI Management software is an http based web GUI which allow the administrator to manage the IPMI devices in the local network. We do not recommended installing the service on a system that hosts the IPMI device.

-
1. Make sure all necessary cables are installed. After connecting the required cables, insert the RocketGuard130 into an available PCI or PCI-X slot (and the RocketRAID card in its corresponding spot)
 2. If you have a firewall configured, make sure TCP ports 7410 and 7411 are not blocked.
 3. Install the latest IPMI Web GUI for the management system (the system you want to monitor devices from).

Double click “setup.exe” - this will start the installation procedure.



Warning: It is not recommended that install the HighPoint IPMI Management Software on Managed system. If you want to manage a remote system, please install the HighPoint IPMI Management in your system first.

IPMI Installation (Windows Operating Systems)

1. Double click “setup.exe” – this will start the installation procedure.



2. Choose the destination location:

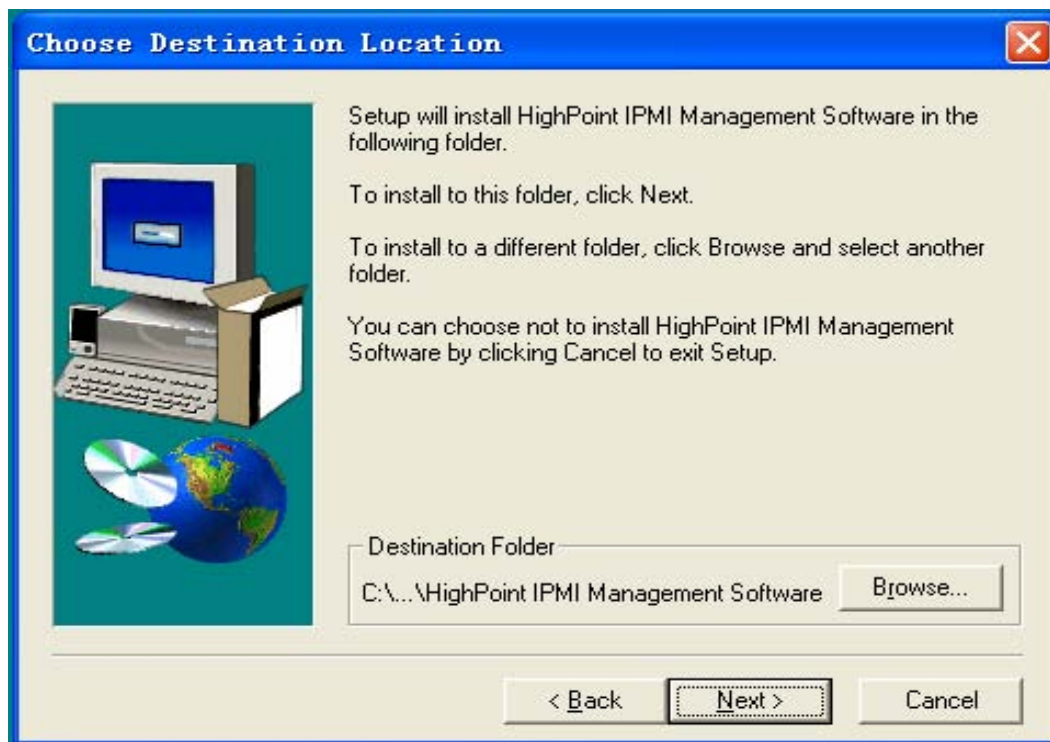

3. Select the components:



Note: One item is available: “HighPoint IPMI Management Service Files”. The Service Files item is the core component of the IPMI utility, and acts as the communication link between the Management interface, and the RocketGuard 130.

4. Specify the folder name for the program icons:



5. Click Finish to complete setup:



Note: To use the web-based IPMI management interface, a web browser with XML support is required, e.g. Internet Explorer 6.0, FireFox, Mozilla. This IPMI management service is restricted to local access.

6. To run the management interface, start your browser and enter the following URL address:

<http://localhost:7410/>

You can also double click the IPMI desktop Icon to access the Management interface login screen.

The Login field is left blank and the password is “admin”. These are the default settings – we recommend altering these settings after logging in for the first time.

3-3 Updating the RocketGuard130 Firmware/Altering device settings

Note: Before running the update program, Please be sure that RG130's I²C is properly connected with RR2xxx HBA Adapter with driver installed and the HighPoint RAID Management utility “hptsvr” service is started.

Window OS	Linux OS
execute update.bat	Please execute "sh ./update.sh" command under Terminal Console (have to be in same directory where you saved the update.sh program)

Run the appropriate update utility (see the above table), to alter settings and update the RocketGuard 130's firmware. The following menu will be displayed:

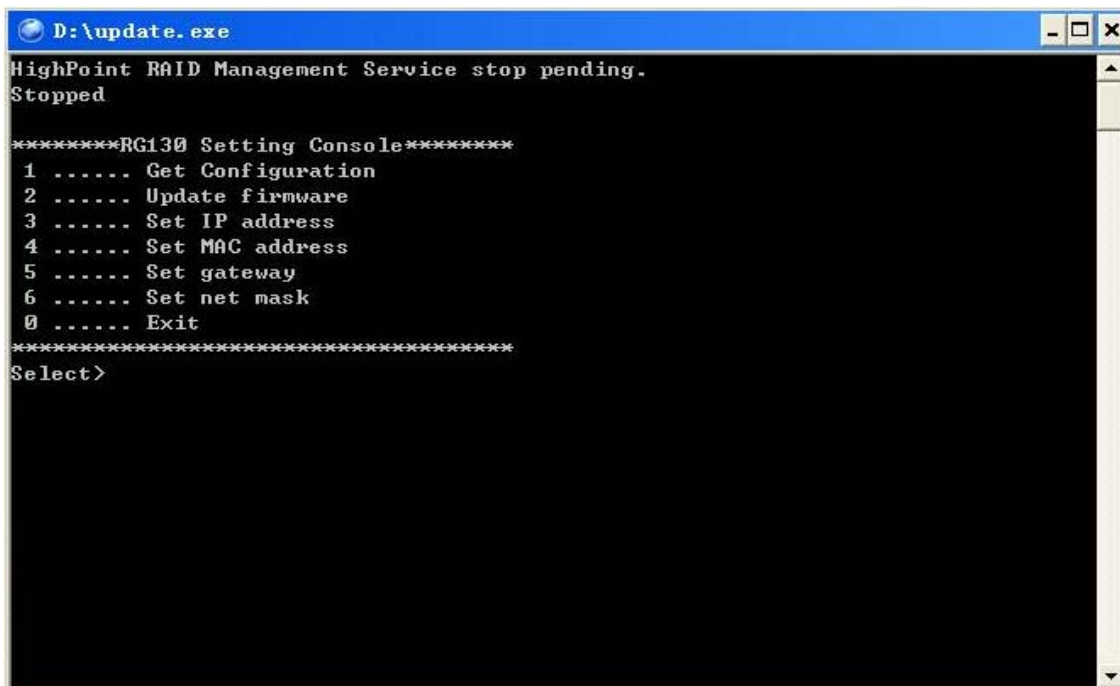

```
D:\update.exe
HighPoint RAID Management Service stop pending.
Stopped

*****RG130 Setting Console*****
1 ..... Get Configuration
2 ..... Update firmware
3 ..... Set IP address
4 ..... Set MAC address
5 ..... Set gateway
6 ..... Set net mask
0 ..... Exit
*****
Select>
```

The utility will provide 7 options. Press the corresponding numeric key to select an option.

1 – This option will display information about the RocketGuard130's current configuration, including the firmware revision, IP address, MAC address, gateway and net mask.

The Firmware version will be presented in the format “X.X.X.X.X”. The first two numbers refer to the IPMI Firmware version number (this information is also provided by the IPMI management Software). This number should change after a successful Firmware is update.

The last three refer to the Update Firmware version number. These will not change.

Note: We do not recommend updating the RG130 using an older firmware revision.

2 – Use this option to update the firmware. You will be asked to input the file path (location) of the firmware update file.

Example: C:\Monitor.abs.s19

3 – This option is used to set the RocketGuard130's IP address. Type in the desired IP address

Example: 192.168.0.36

4 – This option is used to set the RocketGuard130's MAC address. Type in the appropriate MAC address.

Example: 00-19-3C-85-2A-6F

5 – This option is used to set the RocketGuard130's gateway. Enter the appropriate gateway address.

Example: 255.255.255.0

6 – This option is used to set the RocketGuard130's net mask. Enter the appropriate net mask.

Example: 192.168.1.1

7 – Use this option to exit the utility.



Warning: Please do not close the utility window or shut down the computer during the firmware update procedure. Doing so may result in irreversible damage to the RocketGuard 130.

Chapter 4

HighPoint IPMI Management Software

4-1 Overview

This management software is based on IPMI specification versions 1.5 - 2.0. It is a web-based user interface that allows the system administrator to manage the IPMI Devices in the local network.

To run the software, double click on the HighPoint IPMI Management icon on the desktop.

Note: In order to run this software from a non-localhost remote system, your server must enable that exception. It usually included in a list of IP addresses in which you can change the settings for. For remote systems, map the public address through the internal address. See the server manual for further instructions.

4-2 Host Management

As shown in Figure4, click the “Host Management” menu to access host management page.

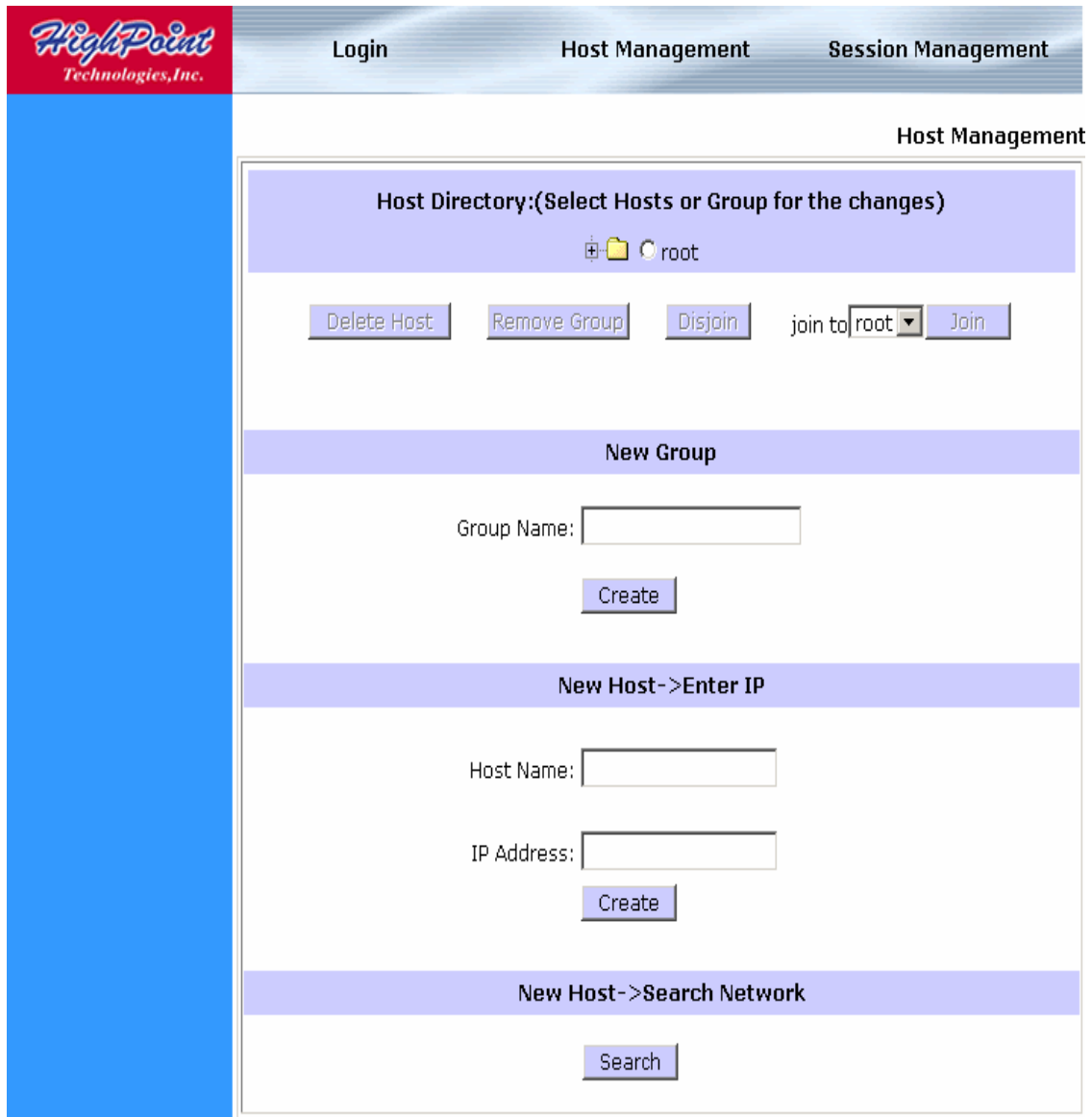

Fig. 4

4-1-1 Add a new group

In the “New Group” section, type in the desired Group Name and click the “Create” button to add a new group. The “Root” group is automatically generated by the Management software. All available hosts will be automatically added into this group.

4-1-2 Add a new host

In the “New Host → Enter IP” section, type in the desired Host Name (optional) and IP Address, and click the “Create” button to add the new host into the “root” group.

4-1-3 Discover new host in a specified network

1. In the “New Host->Search Network” section, click the “Search” button to access the “Search Network” page.

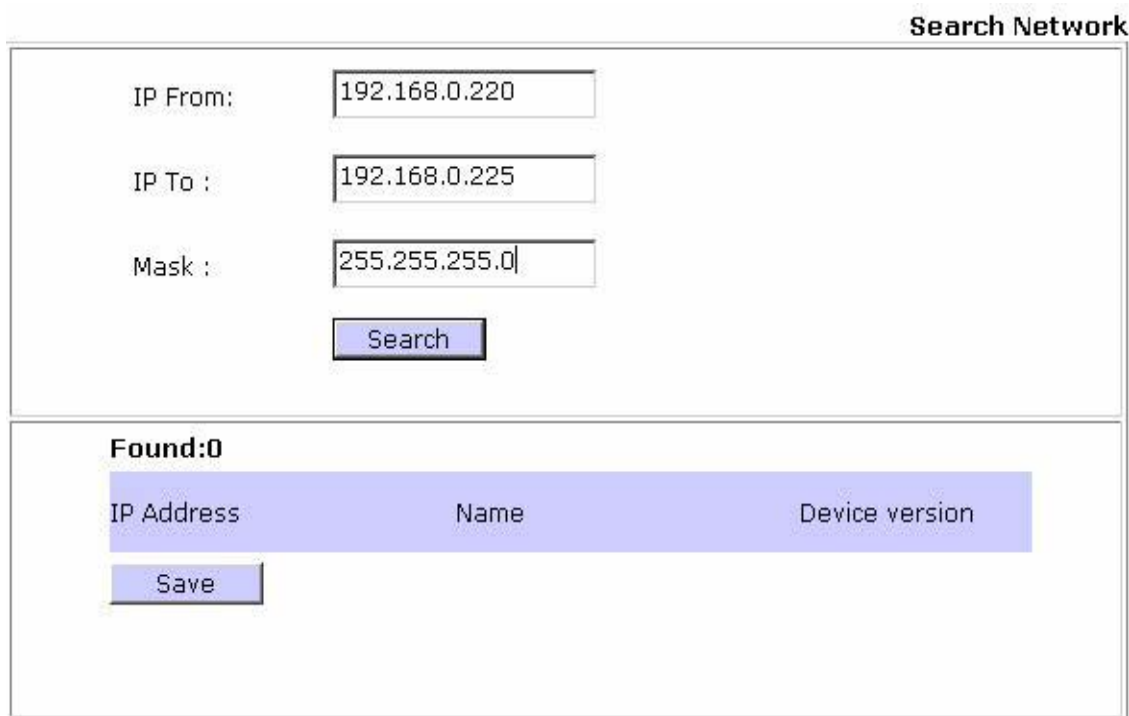

The screenshot shows the "Search Network" interface. At the top right, the title "Search Network" is displayed. Below the title, there are three input fields: "IP From:" with the value "192.168.0.220", "IP To:" with the value "192.168.0.225", and "Mask:" with the value "255.255.255.0". A "Search" button is located below these fields. Below the search fields, the text "Found:0" is displayed. Underneath, there is a table with three columns: "IP Address", "Name", and "Device version". A "Save" button is located below the table.

2. Enter the appropriate values in the “IP From”, “IP To” and “Mask” fields to specify the IP range, then click “Search” to locate all available systems that support IPMI 1.5 or IPMI2.0. Once the search is complete, a candidate systems list will be displayed.

Search Network

IP From:

IP To :

Mask :

Found:1

IP Address	Name	Device version
<input type="checkbox"/> 192.168.0.223	<input type="text" value="192.168.0.223"/>	2.0

3. Select the desired system from the candidate list, and enter a new host name. Click the “Save” button to save the candidate system.

4-1-4 Delete Host

Expand the host directory and select the target group and host. Click the “Delete Host” button.

4-1-5 Remove Group

Select the target group, then click the “Remove Group” button.

4-1-6 Disjoin Group

Expand the host directory and select the group and host. Click the “Disjoin” button.

Note: You cannot Disjoin Hosts in the Root group.

4-1-7 Join Group

Expand the host directory and select the source group, host, and destination group, then click the “Join” button.

4-3 Login

As shown in Figure 5, click “Login” menu to access the “Select Host” page.

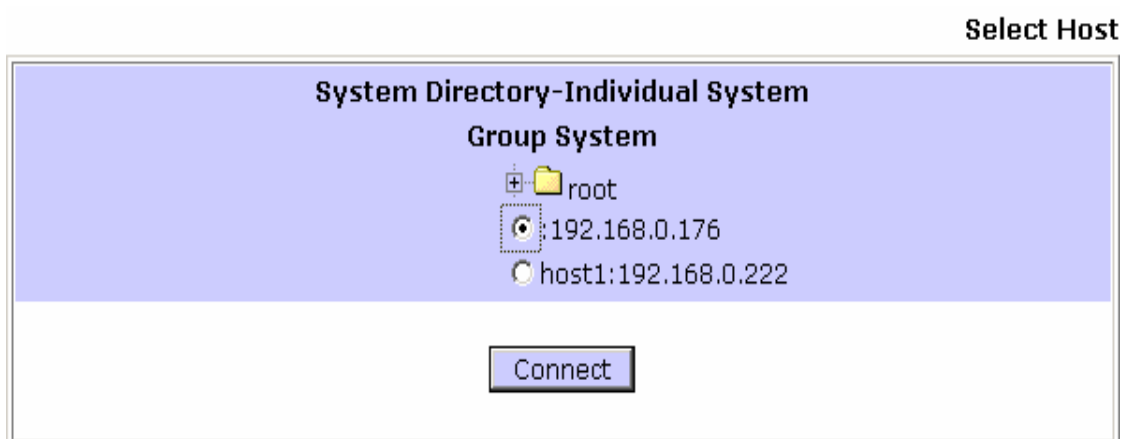

Select a host from system directory then click the “Connect” button to access the “IPMI Session Authentication” page.

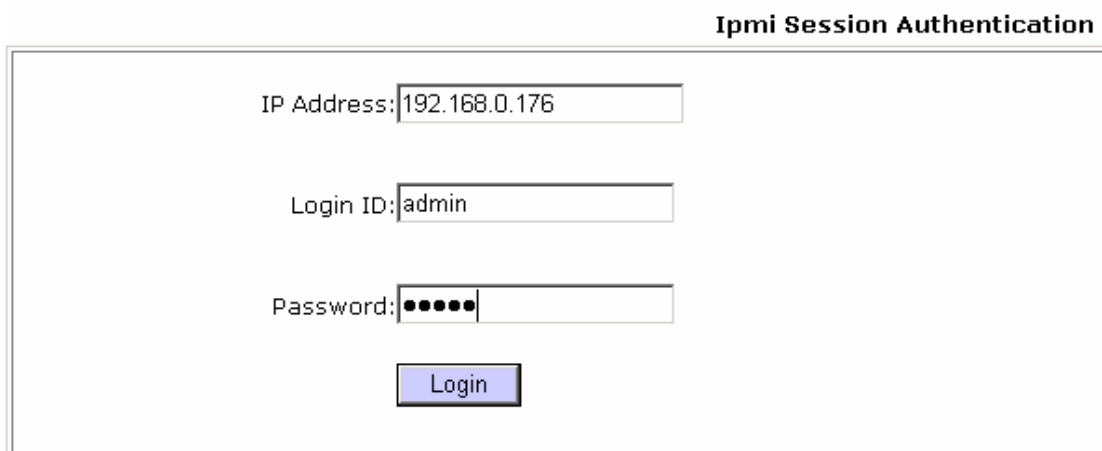

Enter the appropriate values into the “IP Address”, “Login ID” (optional) and “Password” (optional) fields, then click “Login” button. After a successful login, the chassis power control page will be displayed (Figure 6).

Note: The Rocket Guard’s initial user is left blank and password is “admin”.

You can manage several IPMI hosts at the same time. Use the “Session Management” Menu to switch between them.

4-4 Session Management

4-4-1 Choose Session

When managing multiple systems, select “Session Management> Choose Session” in the pull-down menu to switch between the active sessions. Select the management session you want to control, then click “choose” button.

4-4-2 Close Session

When managing multiple systems, select “Session Management> Choose Session” in the pull-down menu to switch between the active sessions. Select the management session you want to close, and click “close” button.

4-5 Remote Boot Console

4-5-1 Chassis Power Control

The screenshot shows the HighPoint Technologies, Inc. Remote Boot Console interface. The top navigation bar includes 'Login', 'Host Management', and 'Session Management'. Below this, the 'Control Functions' section is active, displaying 'Current Host: 192.168.0.223'. The left sidebar lists various management options: Remote Boot Console, Event Log History, System Health Management, Network Configuration, BMC Information, User Management, SOL, SNMP, and Logout. The main content area is titled 'Chassis Power' and 'BMC Power'. It displays 'Chassis Power State: off' and 'Chassis Power Control'. Below this, there are two rows of buttons: the first row contains 'Power Cycle', 'Shut Down', 'Power Up', and 'Reboot'; the second row contains 'Graceful Power Cycle', 'Graceful Power Off', and 'Graceful Power Reset'.

This page is used to forcibly control the power state of the managed system's chassis. When the BMC receives a chassis power control command, it will have direct control over the power button or reset functions of a system.

- **Reboot:** This is the equivalent of pressing the system chassis's Reset button (hardware power reset).
- **Shut Down:** This command will power down server (the equivalent of holding down the power button while the system is active).
- **Power Up:** This command will power up the server (the equivalent of cold-booting the system).

-
- **Power Cycle:** This function is a combination of the Power Down and Power Up commands. The Power Cycle function will shut down the managed system for a few seconds, and then power up the system.

4-5-2 Graceful Power Control

Graceful power control will instruct the OS running on the managed system to shut down/reboot/power cycle within a specified time. When the OS running on the managed system receives a graceful power control request, it will generate a pop-up window on the managed system's monitor and start a count down.

Note: If the graceful power functions do not work, make sure the RocketRAID driver and GUI are installed properly.

- **The Web RAID management Service** (which supports graceful power control) should be running in the background.
- **Graceful Shutdown:** This is the equivalent of using the shutdown function in Windows. The managed system will enter an S5 state.
- **Graceful Reboot:** This is the equivalent of the reboot function in Windows.
- **Graceful Power Cycle:** This function is a combination of the Graceful Shutdown and Power Up functions. The Power Cycle function will shut down the managed system for a few seconds, and then power up the system.

-
- **BMC Cold Reset:** This allows you to reset the BMC. After resetting the BMC, the session will break immediately - the user has to login again. This function is rarely used - only in the case of a suspected software/hardware failure.

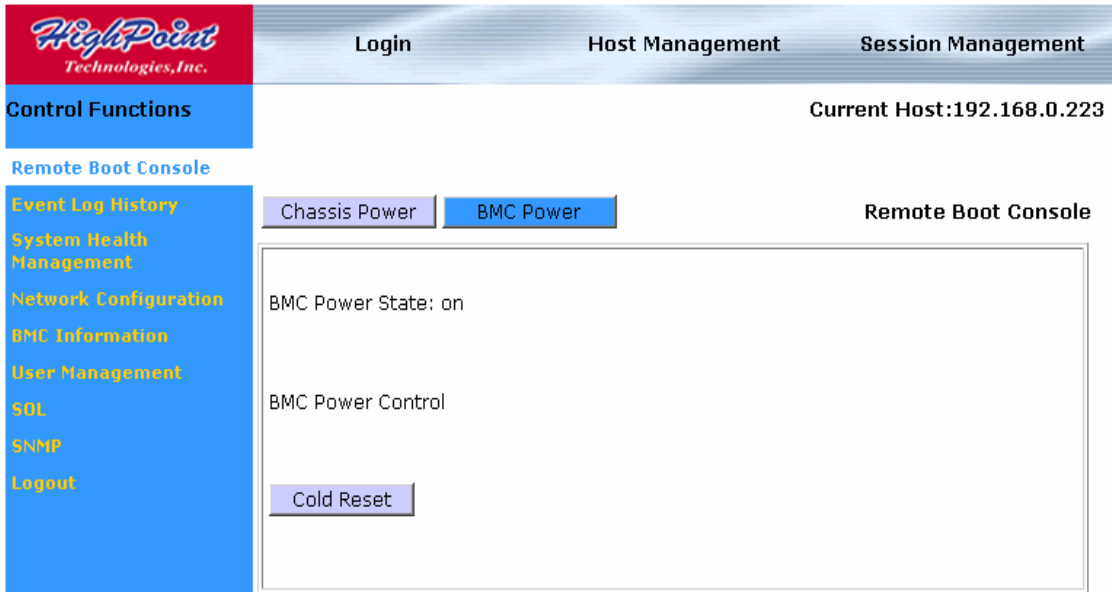

4-6 Event Log

Click the “Event Log History” function to view detailed information reported by the System Event Log for the BMC. It will display the System Event Log version, number of log entries, remaining free space available for System Event Logs, and the time/date of recently added and/or recently erased System Event Logs.

HighPoint Technologies, Inc. Login Host Management Session Management

Control Functions Remote Boot Console Event Log History System Health Management Network Configuration BMC Information User Management SOL SNMP Logout

Event Log Time Stamp Event L

Current Host:192.

ELH Information

Total Entries:4
 Available Space:4032
 Last Entry Erased:N/A
 Last Entry Added:12/31/2005 13:32:54

Retrieve ELH Information

All Entries
 Select From 1 To 4
 Display

Number	Sensor Name	Sensor type	Date	Description
1	System	temperature	12/31/2005 13:32:29	Upper Critical high
2	System	temperature	12/31/2005 13:32:35	Upper Critical low
3	Fan5	fan	12/31/2005 13:32:48	Device Present
4	Fan5	fan	12/31/2005 13:32:54	Device Absent

Erase Save

- **Get System Event Log**

Type in the first and last numbers of the logs you wish to view, or click the “All Entries” button. Then, click the “Display” button to view all the logs from the BMC. The logs retrieved from the BMC will be displayed as a table towards the bottom portion of the web page.

- **Clear System Event Log**

Clicking the “Erase” button clears the logged system events on the BMC. When all available event log space is used, any incoming event data will be lost. The user must clear the system event log manually, as needed.

- **Save System Event Log**

Clicking the “Save” button saves the logged system events on the BMC to local disk.

4-7 Time Stamp

Click the “Time Stamp” button to display the **Time Stamp** page. Type in the time stamp string, then click “Save” to set the time stamp of the BMC on the managed system. If the BMC loses power and restarts, the time stamp will be automatically set by the HighPoint Web RAID Management Service.

4-8 System Health Management

Clicking on the “System Health Management” menu selection will provide you with detailed information about sensors monitored by the BMC. It will display readings of supported voltages and fan speeds and temperatures monitored by the BMC. The high limits/low limits reading is shown in red numbers.

4-8-1 Set High/Low limit

Select sensor name and high/low limit and type in value to set high/low limit.

4-8-2 Buzzer

If the System temperature is higher than System temperature threshold, the Buzzer on BMC will beep. Click “Mute” button to mute the Buzzer.

If the buzzer is alert at all times, it shows that the temperature in the chassis is higher than the Threshold Value of Temperature 1 in the GUI. You can modify the Mute Buzzer using the WebGUI.

Note: For the default system, if the temperature is less than 60 degrees Celsius, the fan runs at full speed. However, you can set the value of the Temperature Threshold in order to control the fan speed to accommodate the changing environment.

4-8-3 Hide/Display Invalid Sensor

Click the “Hide” button to hide sensors that are not installed. Click the “Display” button to display all sensors.

4-9 Network Configuration

Clicking on the “Network Configuration” selection from the menu will provide detailed information about the Lan Settings, including IP Address, Gateway IP, Subnet Mask, Lan Mac, Gateway Mac.

HighPoint Technologies, Inc.

Login Host Management Session Management

Control Functions Current Host:192.168.0.223

Remote Boot Console

Event Log History

System Health Management

Network Configuration

BMC Information

User Management

SOL

SNMP

Logout

Network Configuration

Lan Setting

IP Address: 192.168.0.223

Gateway IP: 192.168.0.1

Subnet Mask: 255.255.0.0

LAN MAC: 00:0b:06:e3:40:7b

Gateway MAC: 01:0b:06:e3:40:7b

Update

Select the item you wish to change, type in the new value, and click the “Update” button to modify the lan settings.

The default IP Address is : 192.168.1.1

The default Subnet Mask is : 255.255.255.0

Note: Please make sure that the MAC address of the LAN and the gateway for the BMC are correct before making any changes. Be careful to enter the correct values, especially for the LAN MAC. If you enter the wrong LAN MAC value, IPMI View will no longer be able to connect to that system.

If you accidentally enter a wrong LAN MAC value, use the Update.exe command located in the utility subfolder on this CD to update it.

4-10 BMC Information

Clicking on the “BMC Information” selection from the menu will display the IPMI version, firmware version, and Manufacturer.

The screenshot shows the HighPoint Technologies web interface. The top navigation bar includes 'Login', 'Host Management', and 'Session Management'. The left sidebar menu is expanded to show 'BMC Information' in blue. The main content area displays the following information:

BMC Information	
IPMI Version:	2.0
Firmware Version:	1.1
Manufacturer:	HighPoint Technologies

Additional information visible on the page includes 'Current Host: 192.168.0.223' and 'Control Functions'.

4-11 User Management

Clicking the “User Management” selection from the menu will display the User Management page:

HighPoint Technologies, Inc.

Login Host Management Session Management

Control Functions

Remote Boot Console

Event Log History

System Health Management

Network Configuration

BMC Information

User Management

SBL

SNMP

Logout

Current Host:192.168.0.223

User Profile

Userid	Username	privilege
1		administrator

DeleteUser

User Name:

Password:

Privilege: administrator

Password:

Privilege: administrator

This function is used to manage user information and included the following functions: **Delete User**, **New User**, **Set user Privilege** and **Set user Password**.

4-11-1 New User

Click the “New User” button. Input the user name, password, and select the privileges.

4-11-2 Delete User

Select the user id you want to delete, then click the “Delete User” button.

4-11-3 Reset Password

Select a user id you want to modify, type in new password, then click the “Reset Password” button.

4-11-4 Reset Privilege

Select the user id you want to modify, select new privilege, then click the “Reset Privilege” button.

4-12 SNMP

This displays the SNMP trap configuration of the system that needs to receive the SNMP traps generated by the BMC, and allows you to modify them. To change the community, type in the SNMP community name in the “Community” text field, and then click the “Update” button.

The SNMP Trap may have multiple destinations. When any critical error occurs, an SNMP trap packet will be sent to all receivers in the list. To add an SNMP receiver, you may change both the IP and MAC addresses to X. X. X. X and XX: XX: XX: XX: XX: XX respectively, then click the “Add” button. When you want to delete an SNMP receiver, choose the proper IP address, then press the “Delete” button.

When you receive an SNMP trap, it will be shown towards the bottom of this window. Pressing the “Erase traps” button will delete it.

Note: Before using this function, you must properly configure your firewall port. Add a new UDP port as an exception, and use the port number 162. Follow the steps below:

- Go to Control Panel (Classic View.)
- Double click on Windows Firewall and then click on the

Exceptions tab at the top.

- Add a UDP port in Exceptions page
- Set the port to 162 and click OK.

4-13 SOL Console

4-13-1 2 X 5 Pin Serial Cable for Serial over LAN

This cable is used for Serial over LAN (SOL). It connects the RocketGuard130 COM port (J1) to the motherboard's COM1 or COM2 port.

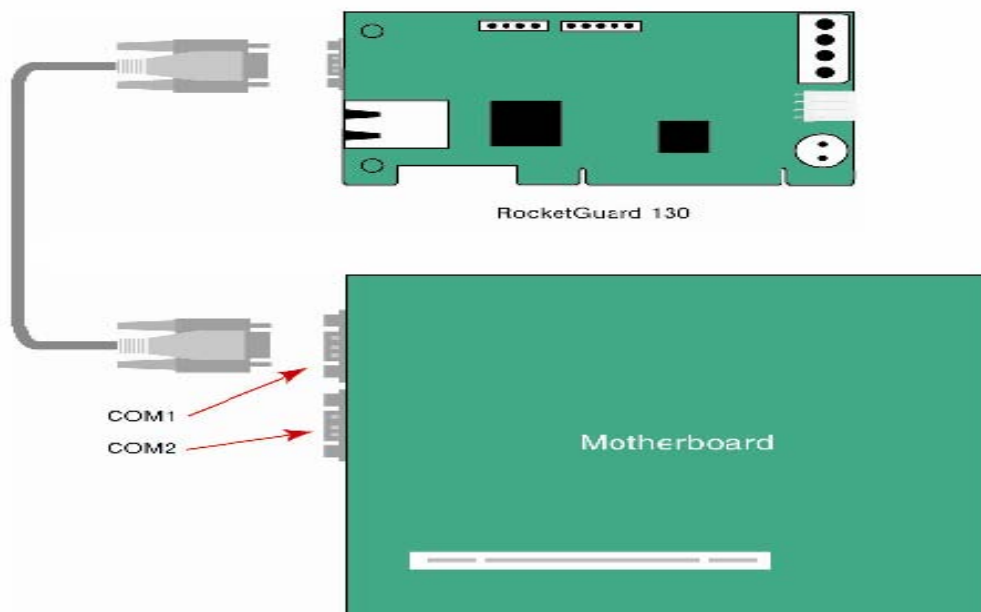

4-13-2 Configuration

If you want to use SOL to monitor or change the motherboard's BIOS settings, please make sure to utilize a motherboard that supports "Console Redirection".

a. Access the motherboard's BIOS settings menu, and choose "Console Redirection", for example: choose "COM1", as follow:

Baud Rate: 19.2K

Flow Control: None

Console Type: PC ANSI

b. You can choose to enter LINUX or Windows:

For LINUX: You will need to modify two files - add the line of "S1: 12345:respawn:/sbin/agetty -L 19200 ttyS0 vt100" to the "/etc/inittab" file. And, add the file "ttyS0" to the "etc/securetty" file.

For Windows: To support Text Console Redirection on Windows 2003 system, Special Administration Console (SAC) must be enabled. The following guide will describe how to enable SAC:

Modify the "boot.ini" located in the root of drive C:\. The boot.ini is a hidden file. Below is an example of the boot.ini file:

[Boot loader]

Redirect=com2

redirectbaudrate=19200

Timeout=30

default=multi(0)disk(0)rdisk(0)partition(1)\WINDOWS

[operating systems]

multi (0)disk(0)rdisk(0)partition(1)\WINDOWS="Windows

Server 2003, Standard” /fastdetect

/redirect

Note: In the above file, “COM2” can be changed to correspond with the COM Port you connected to.

4-13-3 Use

Before using, please make sure:

- The motherboard BIOS supports Console Redirection. Make sure this function has been enabled, and redirected to the correct COM port (the port which is connected to RocketGuard130).
- Make sure the HighPoint IPMI Management software has been installed correctly.
- Make sure the appropriate JAVA software has been installed correctly. If you do not have the correct software, you can download the required updates from <http://www.java.com/>. (For detailed information about installing java; please refer to [Chapter 5 Appendix.](#))
- Add a TCP port as an exception in the firewall. Use port number 7410.

After checking all of the above items:

Windows - you can launch “HighPoint IPMI Management.exe” from the start menu.

Linux - please run the “/usr/bin/hptsol” application.

Open your web GUI interface: after logging in, you will see the SOL on the left menu. Press it to display the SOL window. Click Activate button to activate the SOL function.

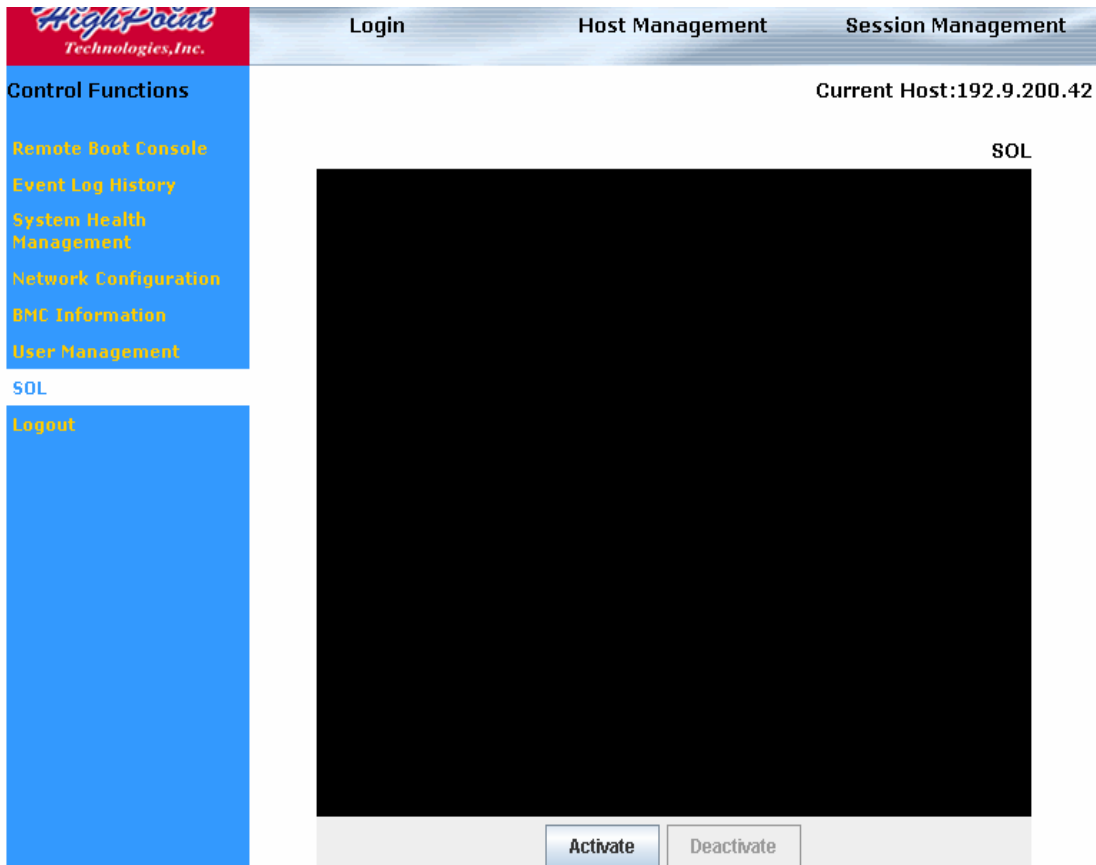

Then, press any key to continue using the SOL function. If you want to quit SOL, please press “Deactivate”.

4-14 Firewall

The HighPoint IPMI Web GUI will use two TCP ports: 7410 and 7411. The SNMP function will use a UDP port (number 162).

Chapter 5 Appendix

5-1 Steps of installing java under redhat:

1. Download and install files from http://www.java.com/zh_CN/download/manual.jsp

Select Linux RPM (self-extracting file)

As an example, we will use the filename “jre-1_5_0_06-linux-i586-rpm.bin”, and the web browser Firefox.

2. Execute the downloaded file “./jre-1_5_0_06-linux-i586-rpm.bin”

3. Finish installing, adding environmental variable in the file /etc/profile

```
JAVA_HOME=/usr/java/jre1.5.0_06
```

```
JRE=/usr/java/jre1.5.0_06
```

```
CLASSPATH=$JAVA_HOME/lib:$JRE/bin:.
```

```
PATH=$PATH:$JAVA_HOME/bin:$JRE/bin:.
```

```
Export JAVA_HOME JRE CLASSPATH PATH
```

4. Locate the directory in which the web browser (Firefox) is installed:

It must be located in /usr/lib/firefox-1.0.4/

Entering /usr/lib/firefox-1.0.4/plugins

Link file by “ln -s /usr/java/jre1.5.0_06/plugin/i386/ns7/
libjavaplugin_oji.so”

5. Start Firefox and select “enable java”

5-2 Steps of installing Java under Windows

1. When you login to <http://www.java.com/>, the website will check your system, and recommend updates that are appropriate for your OS.
2. Download the recommended software.
3. Double click the Setup installer and follow the prompts.

Chapter 6 Customer Support

6-1 Troubleshooting Checklist

If you encounter any problems while utilizing the RocketGuard 130, or have any questions about this or any other HighPoint product, feel free to contact our Customer Support Department.

Troubleshooting Checklist

Before contacting our Customer Support department:

Make sure the latest BIOS, driver and RAID Software have been installed for the RocketRAID controllers. Updates are available from our website.

Prepare a list of the computer system's hardware and software (motherboard, CPU, memory, other PCI devices/host adapters, operating system, applications)

Contact Information

E-mail address: support@highpoint-tech.com

Phone: 408-942-5800 (request for support)

9:00AM-6:00PM, Pacific Standard Time

Additional information about HighPoint products is available from our web site:

<http://www.highpoint-tech.com>